

Control

CONNECTOR



(AI500 Rev E – 01Mar16)

Hawke International
UK Office,
Oxford Street West,
Ashton-under-Lyne,
Lancashire.
OL7 0NA. UK

Sales: +44 (0) 161 830 6698
Technical: +44 (0) 161 830 6697
Fax: +44 (0) 161 830 6648
E-mail: sales@ehawke.com

Connection Solutions
www.ehawke.com

HAWKE
International



IMPORTANT NOTE

1. Hawke International does not recommend the use of their ControlEx Connectors in applications where rigid PVC / SWA / PVC power cabling (typically to BS 6346 standards) is used in portable / semi-portable applications.
2. Barrier type glands must be fitted to flexible power and loose filled control cabling entering the connectors to maintain the Exd protection concept and to reduce the potential for core movements within the cable being transferred to the connector's internal components. **Where connectors are terminated to topside umbilical cables, or portable connectors, a barrier type cable gland should always be used.**
3. Hawke Ex Connector products are designed to be used in multi-voltage applications in circuits up to 660V AC/DC. It is possible that on certain installations, there may be a mix of applications utilising different voltages on the Connector products. In these instances, the installer / circuit designer must ensure that the plugs and sockets, or their associated cabling, is clearly marked with the correct circuit voltage and current rating to ensure that the equipment being supplied is matched correctly with the supply voltage. The variable insert positions which are a feature of the Connectors may also be used to provide additional means of safety in these applications.

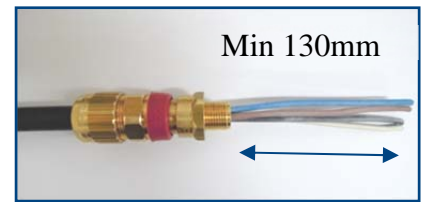
1. Remove the CP/CR connector assembly, electrical insert and cable gland (sold separately) from their packaging.
2. Terminate the cable into the cable gland in accordance with the manufacturer's Instructions. Ensure a minimum tail length of 130mm.

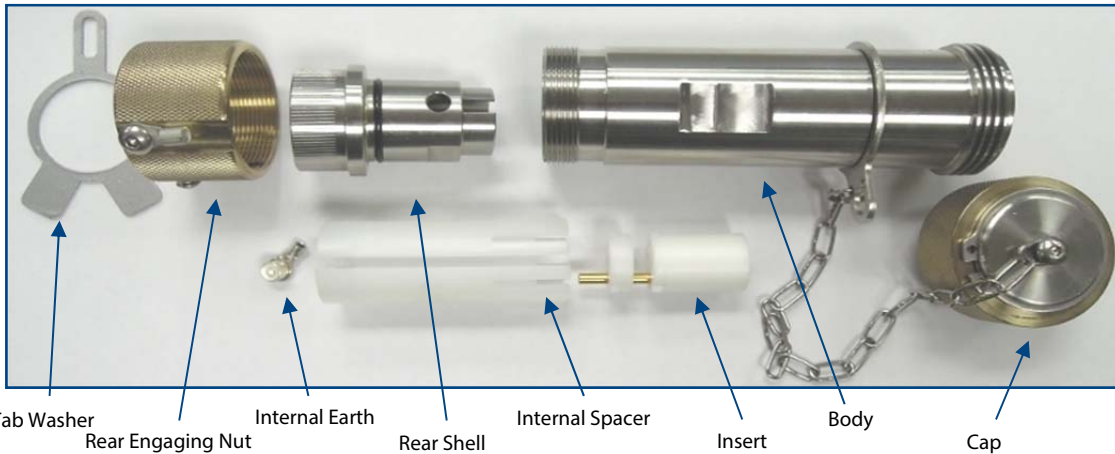

3. **Unscrew the rear engaging nut** from the connector shell, removing the rear shell and keyway tube.



4. Slide the rear engaging nut over the rear shell as shown and screw the rear shell onto the entry thread of the cable gland ensuring there is a sealing washer between the gland and rear shell. A small amount of Loctite 638 or equivalent can be added to the cable gland thread at this stage to further help prevent loosening of the cable gland in portable applications.

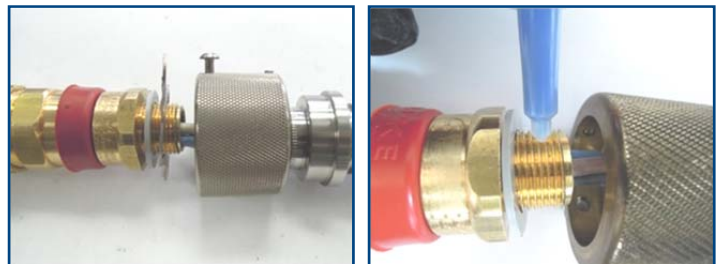

Where a thread adaptor is being used, ensure a suitable IP seal is fitted between the cable gland and thread adaptor, and thread adaptor & running coupler. If the thread adaptor has an integral O-Ring, please ensure this makes full contact with the cable gland and running coupler to maintain the IP protection. Check to ensure the captive O-Ring seal on the rear shell is in place and is undamaged

If the tab washer is being used, ensure this is fitted in the orientation shown. Use the flats on the rear shell to further tighten.

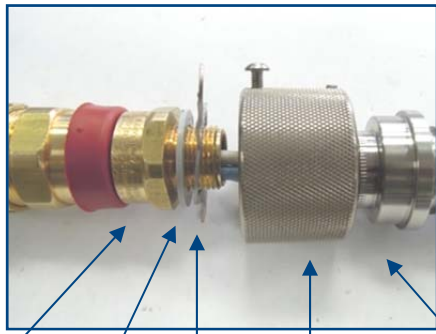

Cable Gland IP Washer Tab Washer Running Coupler Rear Shell



Tighten cable gland to rear shell as shown

5. Cut the conductors to the length shown in the table below.

Insert Type	16	25	32	40	50	63
1.5 & 2.5mm ² Solder / Crimp	36 – 0 +7	56 – 0 +7	56 – 0 +10	56 – 0 +10	56 – 0 +10	56 – 0 +15
6mm ² Crimp	-	38 – 0 +4	38 – 0 +4	-	-	-
10 & 16mm ² Crimp	-	-	29 – 0 +4	-	-	-
25 & 35mm ² Crimp	-	-	-	29 – 0 +4	-	-
6mm ² Solder	-	-	52 – 0 +4	-	-	-
10 & 16mm ² Solder	-	-	-	-	-	-
25 & 35mm ² Solder	-	-	-	52 – 0 +4	-	-

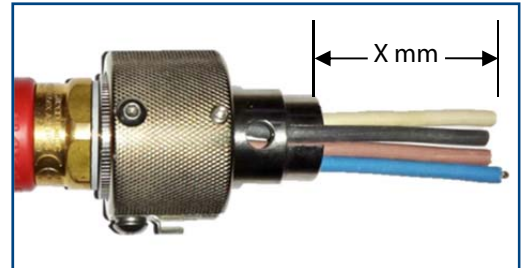

Note: Maximum tolerance is to allow for twisted cables and placement of cores within connector shell. If core spacing relative to insert numbering does not require excess core, use minimum cut lengths.

6. Strip back the insulation from the conductor's as shown

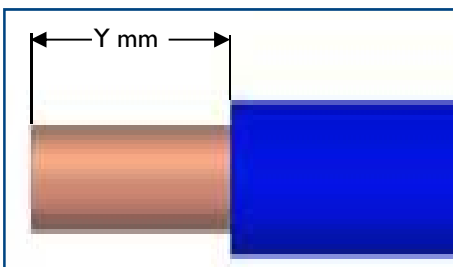

Insert Type	Length (Y mm)
1.5mm ² Solder / Crimp	6
2.5mm ² Solder / Crimp	6
6mm ² Solder	7
6mm ² Crimp	8
10mm ² Solder	9
10mm ² Crimp	11
16mm ² Solder	9
16mm ² Crimp	11
25mm ² Solder	9
25mm ² Crimp	11
35mm ² Solder	9
35mm ² Crimp	11

7. Proceed to step 8 if internal earthing is not required.

NOTE: If internal earthing is not being used, the internal earth crimp **must not** be fitted and the grub screw in the rear shell **must be** removed

If earthing is required slide the internal crimp (supplied with CP/CR inserts) over the earth conductor and crimp using suitable tool. The stud can then be fitted into the rear shell and fastened using the grub screw shown. The stud on the earth crimp should not protrude from the outer diameter of the rear shell. Adjust if necessary.

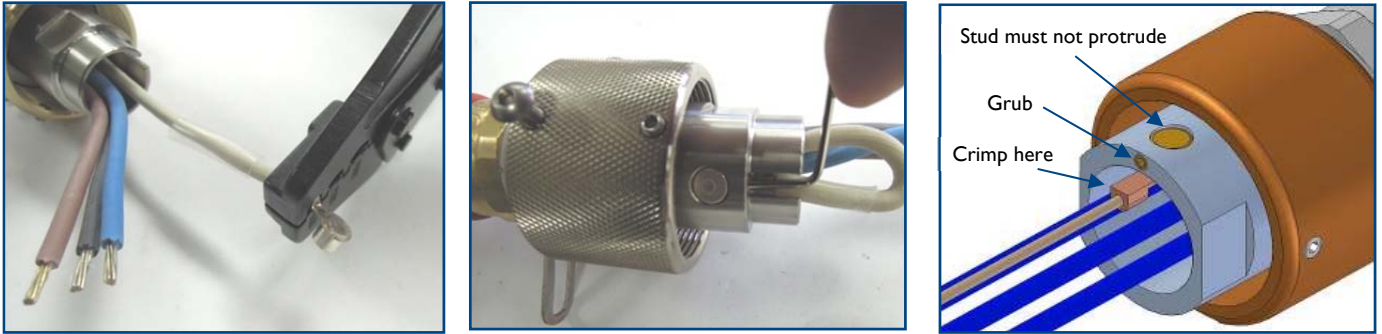

8. a) Solder inserts – black (1.5 – 35mm²). Tin the conductors and fill the solder cups on the back of the inserts with solder as required Solder conductors in place and remove any solder spikes/excess from the solder cup.
It is advised that heat shrink should be fitted over the connection at this point

b) Solder inserts – white (1.5 – 4mm²). As above, however, inserts should be soldered outside of the insert body and not fully assembled. If the contacts are to be solder terminated to the conductors, this must be done prior to insertion through the rear contact retainer.
It is advised that heat shrink should be fitted over the connection at this point

Then follow (c ii & iii).

c) Crimp Inserts (1.5 – 4mm²) – white.

i) Crimp the conductors into the contacts using Weidmuller CTX CM 1.6/2.5 crimp tool HCT1, or Astro Crimp Tool HCT2. For 0.75 to 1.5mm² conductors use the 1.5 die. For 1.6 to 4mm² use the 2.5 die.

It is advised that heat shrink should be fitted over the connection at this point

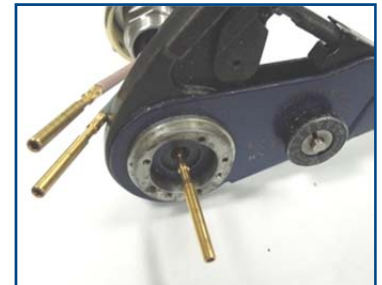

ii) Feed the contacts through the required numbered hole on the rear contact retainer and slide the insertion tool over the contacts up to the groove (one end for pin and one for socket). Clip the groove on the contact into position in the rear contact retainer with the tool.

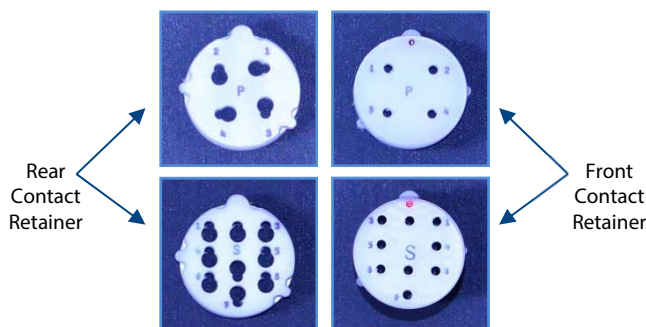

- iii) Align the main pip on the rear contact retainer with the key on the front contact retainer and slide over the contacts into position. Ensure the 2 smaller pips are also in line

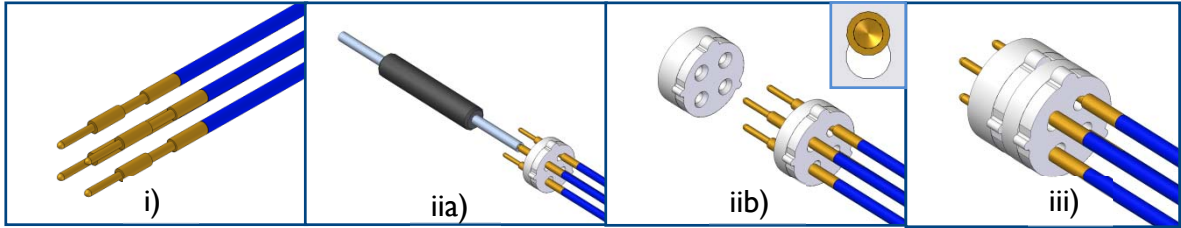

- d) Crimp Inserts (6 – 35mm²) – black. Undo the grub screws on the crimp barrels and slide them off the back of the contacts. Slide the conductors into the back of the barrel. Orientate the barrel so that the grub screws are pointing outwards and crimp with a suitable crimp tool.

Push the barrels back onto the rear of the contacts and tighten grub screw into the groove on the contact. Back off grub screw half a turn on crimp barrels of 10mm² or larger to allow them to slide up and down the contact slightly

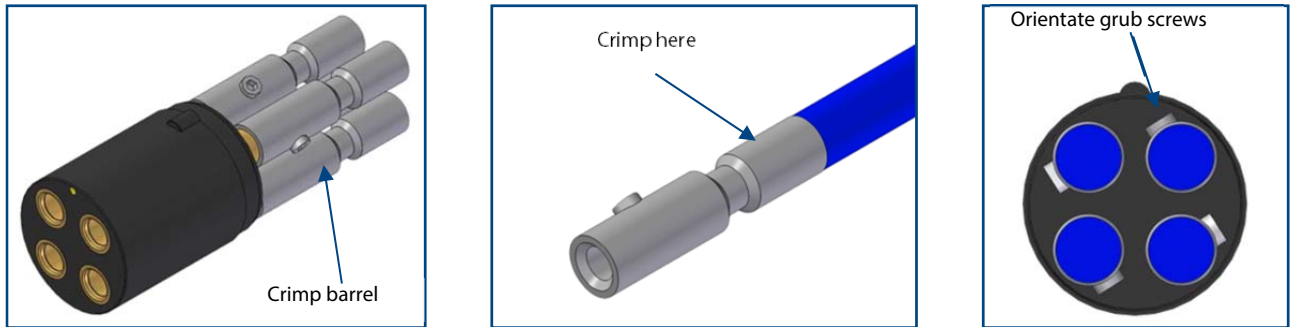

- 9. Clip spacer tube over conductors. Bend conductors slightly so that there is no or minimal gap between the insert/spacer tube and rear shell. On crimp insert of 10mm² or larger, slide the crimp barrels up and down the contacts to achieve this and then lock them in place by tightening the grub screw's on the crimp barrels.

The insert has 3 pips, shown below, which should be located as shown. The main centre keyway should align with the centre of the spacer tube

NOTE: If being used on offshore topside applications where extreme temperature fluctuations or extreme levels of humidity may be present, it is advisable to use Dow Corning 4 Electrical Insulating Compound within the spacer tube to help prevent any possible humidity build-up. See point 15 below

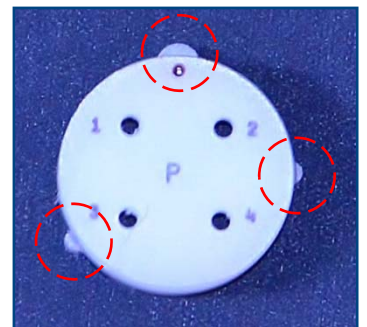

- 10. Looking from the front of the connector shell, align the key on the insert to the required key inside the connector and slide the whole assembly into the shell. The EX16 connector has 3 keyways, and all other connectors have 5 possible keyways



- 11. Fully screw the rear engaging nut onto the thread on the connector shell, do not rotate the connector shell during this process. Tighten grub screw in rear engaging nut. There should be a gap visible of no more than 1mm between running coupler and shell

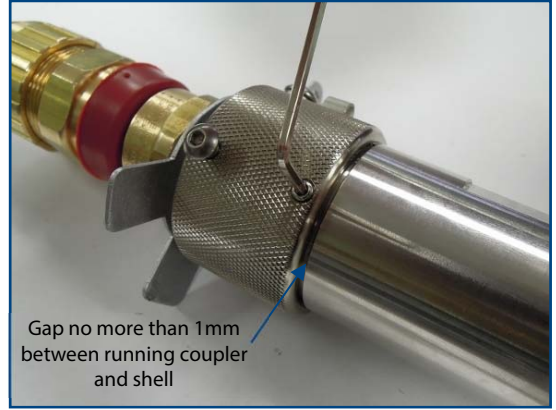

- 12. If the tab washer is being used, fix the tab using the button head screw to the rear engaging nut. Bend the tabs over the flats of the cable gland.
- 13. If being used, terminate the external earth to the ring terminal crimp provided with the insert. Remove the button head screw and spring washer from the rear engaging nut. Attach the crimp to the rear engaging nut as shown above

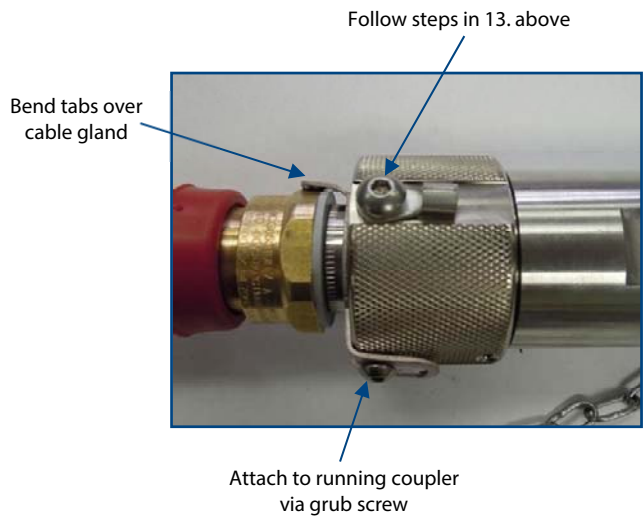

- 14. The connector is now ready for use. Please refer to the 'Hook Up' procedure.

Addition of Dow Corning 4 Electrical Insulating Compound

- 15. If additional protection is required due to extreme atmospheric conditions, before inserting the assembled connector insert and spacer tube into the connector shell (step 10 above) Dow Corning 4 Electrical Insulating Compound can be used to fill the spacer tube. It is recommended that the running coupler be filled, along with the inner face of the insert to ensure no humidity can affect the contacts

MK IV Hook Up Procedure

Before commencing hook up, a visual inspection should be carried out on the cable / gland / connector assembly. The assembly should be checked to ensure that all of the assembly components are tight. If the assembly components have loosened during transportation / cable installation, they should be retightened in accordance with the relevant assembly instruction sheets without twisting the cable in the cable gland / connector assembly.

Areas to be checked:

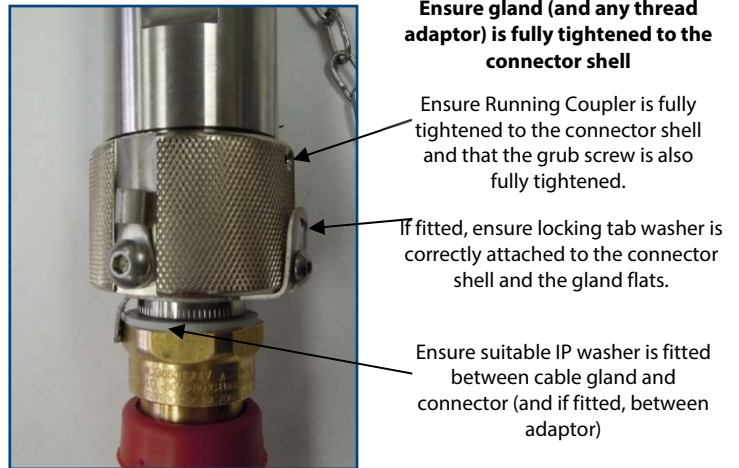

NB: These areas should also be checked as part of a routine maintenance programme.

- 1) Turn off the power to the connectors.
- 2) Ensure the connectors are both set to the same keying position number and are of the same insert type.

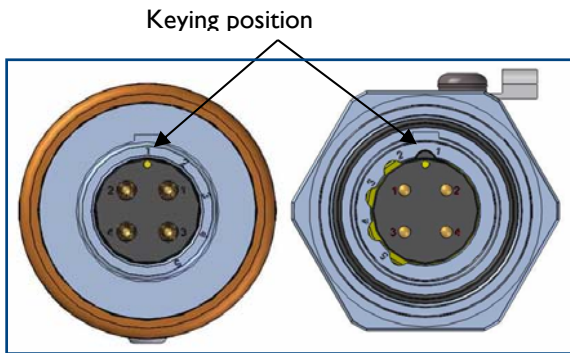

- 3) Engage the CP connector with the BR / CR connector and align the key on the CP connector to the keyway on the BR / CR connector.

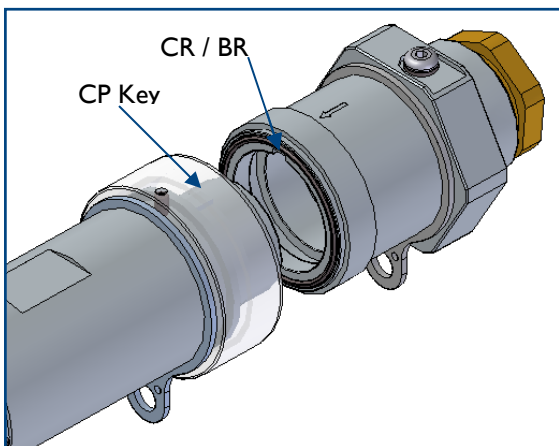

- 4) Engage the two connectors by screwing the engaging nut clockwise onto the BR/CR shell. If the engaging nut will not screw on more than half a turn, then the connectors are set to different keying positions.

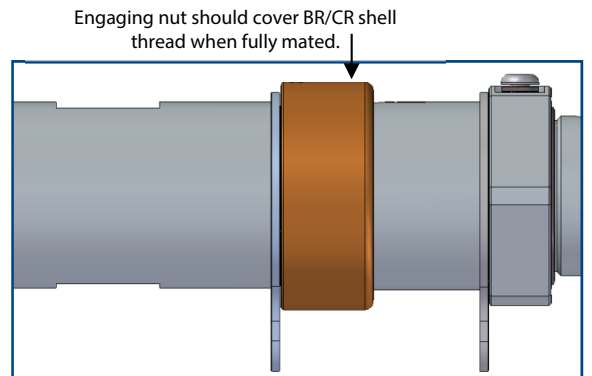

- 5) Tighten the grub screw on the engaging nut.

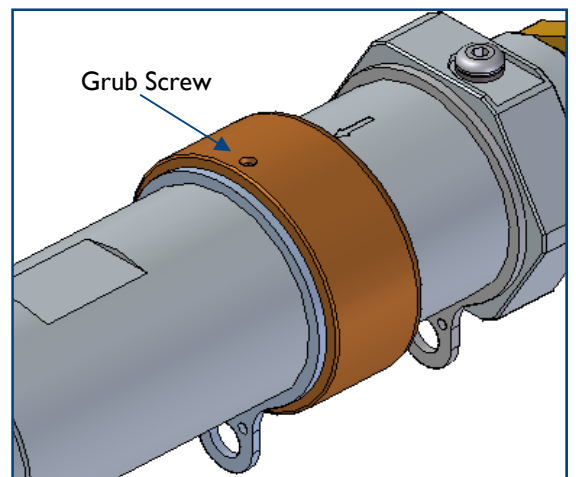

(incorporating AI 501- Connector Hook Up and AI 353 – BR Termination Procedure)

- 6) If the optional locking pin is being used, this should be fitted at this stage, once the connectors are fully mated.

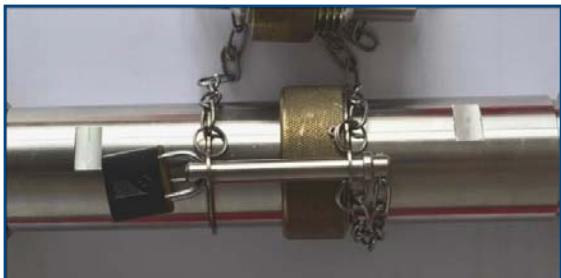

- 7) To disconnect, turn off the power, slacken the tightened grub screw, turn the engaging nut anti-clockwise and remove the connector. If power is to be put through the connectors whilst de-mated, then a flameproof cap (available separately) must be fitted.

MK IV Bulkhead Receptacle Termination Procedure

IMPORTANT NOTE

1. Hawke International does not recommend the use of their ControlEx Connectors in applications where rigid PVC / SWA / PVC power cabling (typically to BS 6346 standards) is used in portable / semi-portable applications.
2. Hawke International recommends that barrier type glands are fitted to flexible power and loose filled control cabling entering the connectors to maintain the Exd protection concept and to reduce the potential for core movements within the cable being transferred to the connector's internal components.
3. Hawke Ex Connector products are designed to be used in multi-voltage applications in circuits up to 660V AC/DC. It is possible that on certain installations, there may be a mix of applications utilising different voltages on the Connector products. In these instances, the installer / circuit designer must ensure that the plugs and sockets, or their associated cabling, is clearly marked with the correct circuit voltage and current rating to ensure that the equipment being supplied is matched correctly with the supply voltage. The variable insert positions which are a feature of the Connectors may also be used to provide additional means of safety in these applications.

- 1) Remove the Electrical Insert assembly and BR Connector assembly from their packaging. Do not throw away the packaging.
- 2) Slide the potting retainer and rubber pot off the back of the electrical insert assembly.

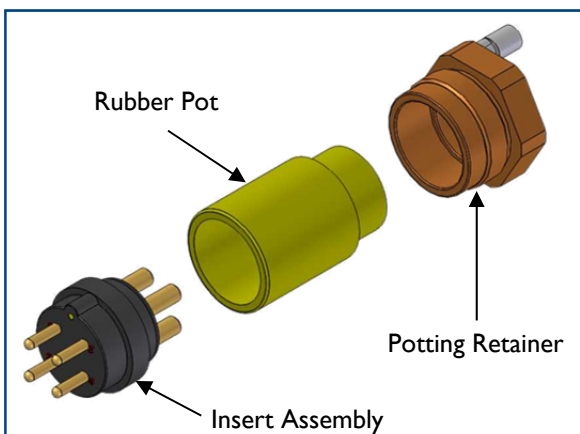

- 3) a) Solder inserts (1.5 – 35mm²).

Tin the conductors and fill the solder cups on the back of the inserts with solder as required. Solder conductors in place and remove any solder spikes / excess from the solder cup.



- b) Crimp Inserts (1.5 – 4mm²).
 - i) Crimp the conductors into the contacts using Weidmuller CTX CM 1.6/2.5 crimp tool part number 901849 only. For 0.75 to 1.5mm² conductors use the 1.5 die. For 1.6 to 4mm² use the 2.5 die. If the contacts are to be solder terminated to the conductors, this must be done prior to insertion through the rear contact retainer.
 - ii) Feed the contacts through the required numbered hole on the rear contact retainer and slide the insertion tool over the contacts up to the groove (one end for pin and one for socket). Clip the groove on the contact into position in the rear contact retainer with the tool.
 - iii) Align the flat on the rear contact retainer with the key on the front contact retainer and slide over the contacts into position.

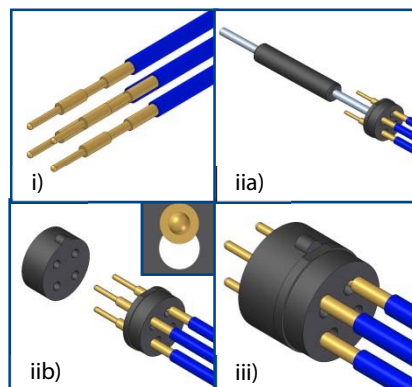

- 4) Slide the rubber pot back onto the insert.

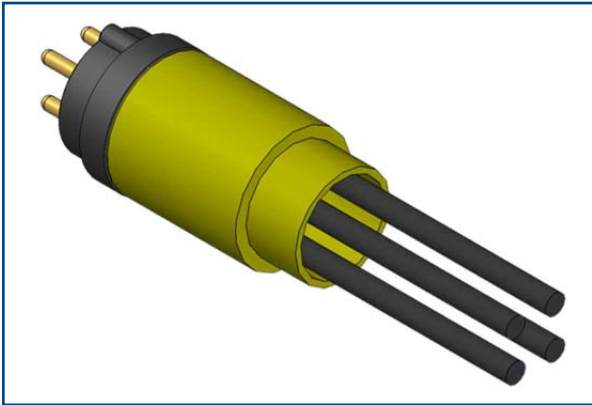

- 5) Stand the insert upright. Secure as necessary.
 6) Remove the compound from the foil packaging. Remove the central barrier separating the compound from the activator. Mix the two thoroughly until the colour of the compound is consistent throughout.

Cut a small hole at the end of the taper in the bag and pour into the rubber pot until flush with the end of the pot. Do not overfill. Leave for 2-3 hours to cure.

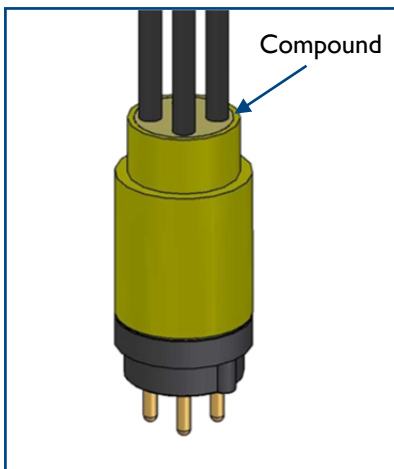

- 7) Peel off any excess compound from the outside diameter of the pot and insert.
 8) Push the electrical insert assembly into the rear of the BR connector assembly. Do not push all the way in.

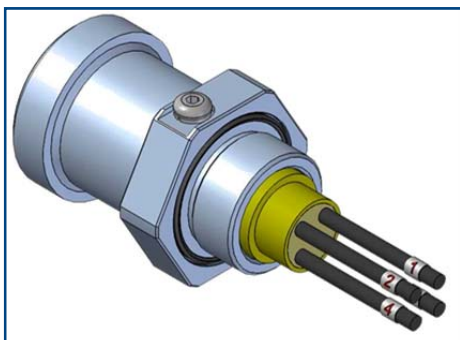

- 9) Rotate the insert assembly until the coloured dot on the face of the insert is aligned to the required keying position.

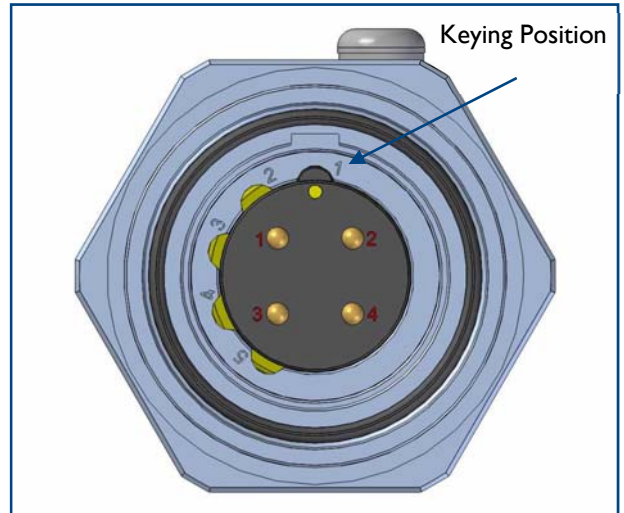

- 10) Push the insert assembly fully into the connector. The insert assembly should no longer rotate and the rubber pot should protrude the distance shown.

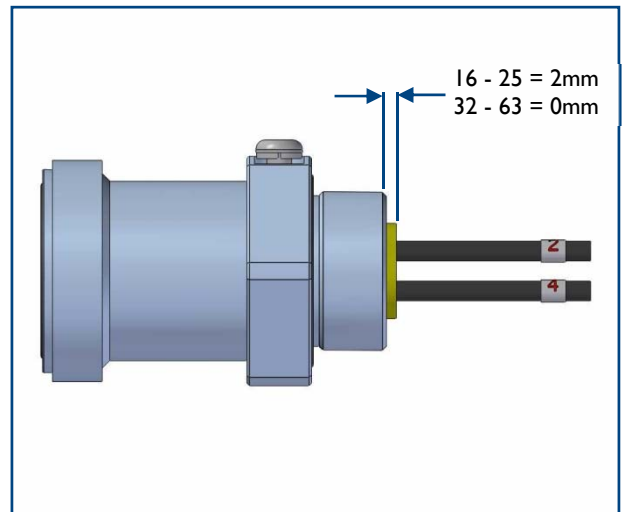

- 11) If an internal earth has been carried through, then an earth conductor (see table right) must be attached to the crimp terminal on the potting retainer. (Earth conductor must be long enough to reach the common earth of enclosure or apparatus).

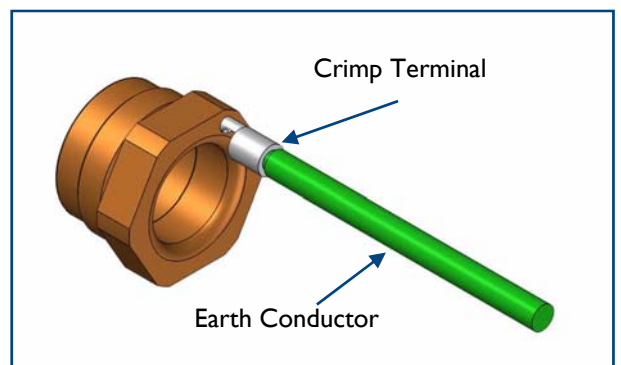

Earth Conductor Information		
Insert Conductor Size	Earth Conductor Size (min)	Supplied Crimp Range
1.5mm ²	4mm ²	2.7 - 6.6mm ²
2.5mm ²	4mm ²	2.7 - 6.6mm ²
4mm ²	4mm ²	2.7 - 6.6mm ²
6mm ²	6mm ²	2.7 - 6.6mm ²
10mm ²	10mm ²	6.7 - 10.5mm ²
16mm ²	16mm ²	10.6 - 16.7mm ²
25mm ²	16mm ²	10.6 - 16.7mm ²
35mm ²	16mm ²	10.6 - 16.7mm ²

- 12) Hand tighten the potting retainer into the BR shell. Now tighten a further 1½ to 2 full turns with a spanner.

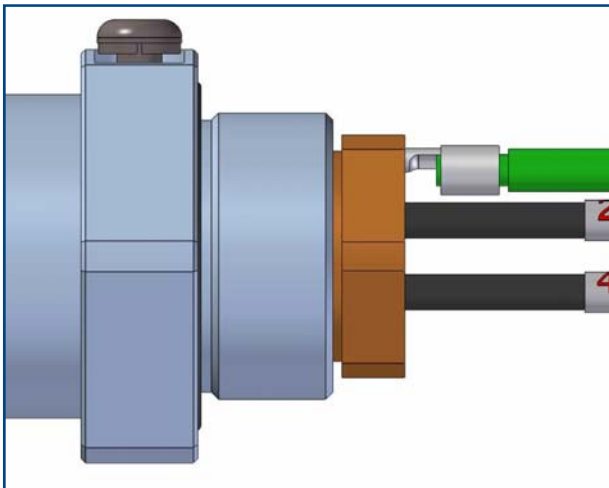

- 13) The connector assembly can now be installed in the enclosure or apparatus. It should be noted that there is a 1.5mm undercut on the entry thread of the BR shell when installing in 'd' rated equipment.

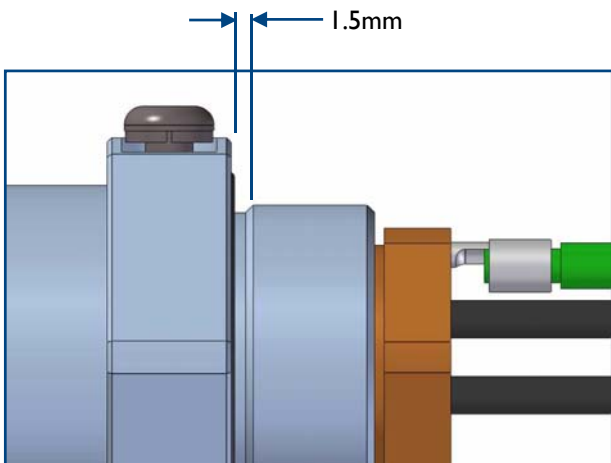

- 14) If an internal earth has been carried through, it must be terminated to the common earth of the enclosure or apparatus. The earth conductor terminated in step 11 must also be attached to the common earth.
- 15) The final step is to terminate the external earth. To do this, remove the button head screw and spring washer from the BR shell. Now terminate the earth conductor (see table in step 11) to the crimp supplied with the insert. Attach the crimp to the BR shell as shown.

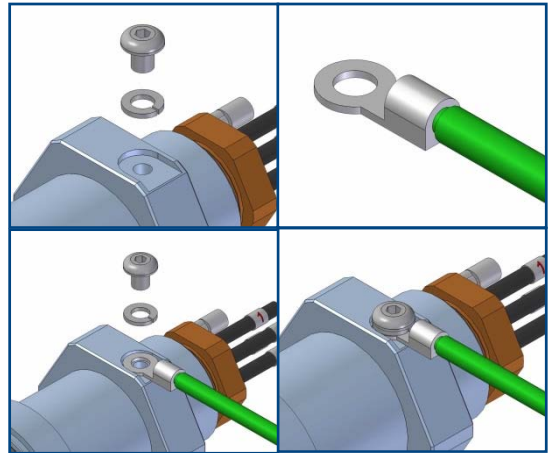

- 16) The connector is now ready for use. Please refer to the 'Hook Up' procedure.

SCHEDULE OF LIMITATIONS

- These connectors must be electrically isolated before any attempt is made to remove the covers or join or separate the two halves.
- When separated the flameproof cap is to be fitted and locked before any associated supply cables are re-energised.
- The cable entry devices selected for use with the in-line connectors shall provide a mechanical cable retention facility appropriate to the cable type and conditions of service.
- The cables terminated within the bulkhead connectors shall be mechanically protected from pulling and twisting, and the potted ferrule shall not be subjected to temperatures exceeding 100°C.
- When used in dust environments the cable entry threads, or bulkhead mounting, shall be sealed in accordance with the installation code of practice to ensure that an ingress protection level of IP66 is maintained.
- Flameproof joints are not intended to be repaired.

AI500 – CONTROL MK IV INLINE CONNECTOR TERMINATION PROCEDURE

(incorporating AI 501- Connector Hook Up and AI 353 – BR Termination Procedure)

CONTROLEX MKIV	Pin configuration	Upper Ambient Temperature of +40°C		Upper Ambient Temperature of +50°C		Upper Ambient Temperature of +60°C		ATEX / IECEx / Inmetro Recommended Max Voltage AC/DC	CSA Recommended Max Voltage AC/DC
		T6	T5	T6	T5	T6	T5		
		Maximum Current per Contact Amps		Maximum Current per Contact Amps		Maximum Current per Contact Amps			
Connector Size									
Ex 16									
3 x 1.5sq mm + Grd	3 x 16 AWG + Grd	9.8	10	8.75	10	7	9.4	750	600
4 x 1.5sq mm + Grd	4 x 16 AWG + Grd	8.5	10	7.6	9.3	6.1	8.15	750	600
Ex 25									
4 x 1.5 sq mm + Grd	4 x 16 AWG + Grd	10	10	9.3	10	7.6	10	750	600
9 x 1.5 sq mm + Grd	9 x 16 AWG + Grd	7.15	8.4	6.2	8	5	6.7	750	600
12 x 1.5 sq mm + Grd	12 x 16 AWG + Grd	6.2	7.25	5.35	6.9	4.38	5.8	750	600
4 x 2.5 sq mm + Grd	4 x 12 AWG + Grd	13.5	15.8	11.7	15	9.5	12.6	750	600
7 x 2.5 sq mm + Grd	7 x 12 AWG + Grd	10.2	12	8.8	11.4	7.2	9.5	750	600
4 x 6 sq mm + Grd	4 x 10 AWG + Grd	19.2	22.5	16.6	21.5	13.5	18	750	600
4 x 6 sq mm + Grd 4 sq mm cable	4 x 11 AWG + Grd	19	19	14	18	11	15	750	600
Ex 32									
12 x 1.5 sq mm + Grd	12 x 16 AWG + Grd	7	8.3	6.2	7.6	5.1	6.5	750	600
19 x 1.5 sq mm + Grd	19 x 16 AWG + Grd	5.6	6.6	4.9	9	4	5.2	750	600
10 x 2.5 sq mm + Grd	10 x 12 AWG + Grd	9.8	11.5	8.5	10.4	7	9	750	600
12 x 2.5 sq mm + Grd	12 x 12 AWG + Grd	8.9	10.5	7.8	9.5	6.4	8.2	1000	600
4 x 6 sq mm + Grd	4 x 10 AWG + Grd	22	25.9	19.2	23.5	15.8	20.4	750	600
4 x 6 sq mm + Grd 4 sq mm cable	4 x 11 AWG + Grd	18	21.0	16.0	19.0	13.0	17.0	750	600
6 x 6 sq mm + Grd	6 x 10 AWG + Grd	18	21.1	15.7	19.2	12.9	16.6	750	600
6 x 6 sq mm + Grd 4 sq mm cable	6 x 11 AWG + Grd	15	17.0	13.0	16.0	10.0	14.0	750	600
3 x 10 sq mm + Grd	3 x 8 AWG + Grd	32.5	38.2	28.4	34.8	23.3	30.1	750	600
4 x 10 sq mm + Grd	4 x 8 AWG + Grd	28	33.1	24.1	30	20.2	26.1	750	600
3 x 16 sq mm + Grd	3 x 6 AWG + Grd	38	44.8	33.3	40.8	27.3	35.3	750	600
4 x 16 sq mm + Grd	4 x 6 AWG + Grd	33	38.8	28.8	35.3	23.7	30.6	750	600
Ex 40									
24 x 1.5 sq mm + Grd	24 x 16 AWG + Grd	5.3	6.3	4.6	5.8	3.7	5	750	600
30 x 1.5 sq mm + Grd	30 x 16 AWG + Grd	4.8	5.7	4.1	5.1	3.3	4.4	1000	600
19 x 2.5 sq mm + Grd	19 x 12 AWG + Grd	7.6	9	6.5	8.2	5.3	7.1	750	600
4 x 25 sq mm + Grd	4 x 4 AWG + Grd	40	48.5	35.3	44	28.6	38.1	750	600
4 x 35 sq mm + Grd	4 x 1 AWG + Grd	44.7	53.2	38.7	48.3	31.3	41.8	750	600
8 x 6 sq mm + Grd	4 x 10 AWG + Grd	16	19.5	14	18	11.5	15.5	750	600
8 x 6 sq mm + Grd 4 sq mm cable	4 x 11 AWG + Grd	14	16.0	12.0	15.0	9.0	13.0	750	600
5 x 10 sq mm + Grd	5 x 8 AWG + Grd	26	32	23	29	18.5	25	750	600
5 x 16 sq mm + Grd	5 x 6 AWG + Grd	31.5	37.5	27	34	22	29.5	750	600
Ex 40 (Special) 4 x 2.5	4 x 12 AWG + Grd	16	17	14	17	11	15	3000	N/A
Ex 50									
37 x 1.5 sq mm + Grd	37 x 16 AWG + Grd	4.5	5.5	3.9	5.1	3.1	4.4	750	600
27 x 2.5 sq mm + Grd	27 x 12 AWG + Grd	6.6	8.2	5.8	7.6	4.6	6.5	750	600
37 x 2.5 sq mm + Grd	37 x 12 AWG + Grd	5.6	7	4.9	6.4	4	5.5	300	600
13 x 6 sq mm + Grd	13 x 10 AWG + Grd	13.5	16.5	11.5	15.5	9.5	13.2	750	600
13 x 6 sq mm + Grd 4 sq mm cable	13 x 11 AWG + Grd	11	14	10	13	8	11	750	600
Ex 63									
37 x 2.5 sq mm + Grd	37 x 12 AWG + Grd	5.6	7	4.9	6.4	4	5.5	750	600
49 x 1.5 sq mm + Grd	49 x 16 AWG + Grd	4.4	5.8	3.9	5.3	3.1	4.4	750	600
60 x 1.5 sq mm + Grd	60 x 16 AWG + Grd	5	6.6	4.4	6	3.6	5	750	600

AI500 – CONTROL MK IV INLINE CONNECTOR TERMINATION PROCEDURE

(incorporating AI 501- Connector Hook Up and AI 353 – BR Termination Procedure)

MAXIMUM DISSIPATED WATTAGE = *W

 II 2 GD Ex db IIC T* Gb (Tamb -40°C to + **°C)

Ex tb IIIC T**°C Db IP66/67

HAWKE OL7 ONA UK

CERTIFICATES:

Baseefa12ATEX0014X IECEx BAS12.0006X CSA 2633583
 Inmetro IEx 14.0216X EAC RU C-GB.G505.B.00750

SERIAL NO: YEAR OF MANUFACTURE / XXXX 6 1180 

WARNING: DO NOT SEPARATE WHEN ENERGISED OR WHEN AN

EXPLOSIVE GAS OR DUST ATMOSPHERE IS PRESENT.

Note: Female thread detail may be added to certification label.

*FILL IN AS APPROPRIATE FROM THE FOLLOWING TABLE

CONNECTOR SIZE	UPPER AMBIENT = 40°C		UPPER AMBIENT = 50°C		UPPER AMBIENT = 60°C	
	TEMP CLASS		TEMP CLASS		TEMP CLASS	
	T6	T5	T6	T5	T6	T5
16	5W	7W	4W	6W	2.6W	4.6W
25	8W	11W	6W	10W	4W	7W
32	10.5W	14.5W	8W	12W	5.4W	9W
40	12W	17W	9W	14W	5.5W	10.5W
50	13W	20W	10W	17W	6.5W	12.5W
63	17W	29W	13W	24W	8.5W	17W

The maximum temperature as for the T Class i.e. T6 = 85°C and T5 = 100°C
 **T5 = 100°C and T6 = 85°C

No maintenance or servicing is required on this product.
 Do not exceed maximum dissipated wattage stated in above table.

Example:

HAWKE / CONTROL  -25 – CP / MAXIMUM DISSIPATED WATTAGE – 13.4W

 II 2 GD Ex db IIC T5 Gb (Tamb -40°C TO + 40°C) – Ex tb IIIC T100°C Db / IP66/67 / HAWKE OL7 ONA UK

ATEX Certificate Number: Baseefa12ATEX0014X

IECEx Certificate Number: IECEx BAS 12.0006X

SERIAL NO: 12/12345 1180 

WARNING: DO NOT SEPARATE WHEN ENERGISED OR WHEN AN EXPLOSIVE GAS OR DUST ATMOSPHERE IS PRESENT.

TYPICAL FEMALE THREAD M20 x 1.5 (Alternative to marking back rings/rear running coupler may be added to table)

EC Declaration of Conformity in accordance with European Directive 94/9/EC (until 19th April 2016) and EU Declaration of Conformity in accordance with European Directive 2014/34/EU (from 20th April 2016)
Manufacturer: Hawke International
Address: Oxford Street West, Ashton-under-Lyne, OL7 0NA, United Kingdom

Equipment: ControlEx MK IV Ex 16 to Ex63

Provisions of the Directive fulfilled by the Equipment:
 Group II Category 2GD Exdb IIC Gb, Extb IIIC Db – IP66
Notified Body for EC-Type Examination: SGS – Baseefa 1180 Buxton UK
EC-type Examination Certificate: Baseefa12ATEX0014X
Notified Body for production: SGS – Baseefa 1180 Buxton UK
Harmonised Standards used:
 EN 60079-0:2012, EN60079-1:2014, EN60079-31:2014

On behalf of the above named company, I declare that, on the date the equipment accompanied by this declaration is placed on the market, the equipment conforms with all technical and regulatory requirements of the above listed directives.

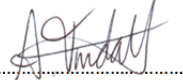

A. Tindall
Technical Manager